

CABLE GLAND INSTRUCTIONS

SEAVIEW

For Cable Gland Part Numbers

CG20P-G

CG30P-G

CGM17P-G

CG20A-B

CG30A-B

CGM17A-B

CG20-SS

CG30-SS

CGM17-SS

Refer to website for most up to date instructions and videos.

www.seaviewglobal.com

TOOLS NEEDED

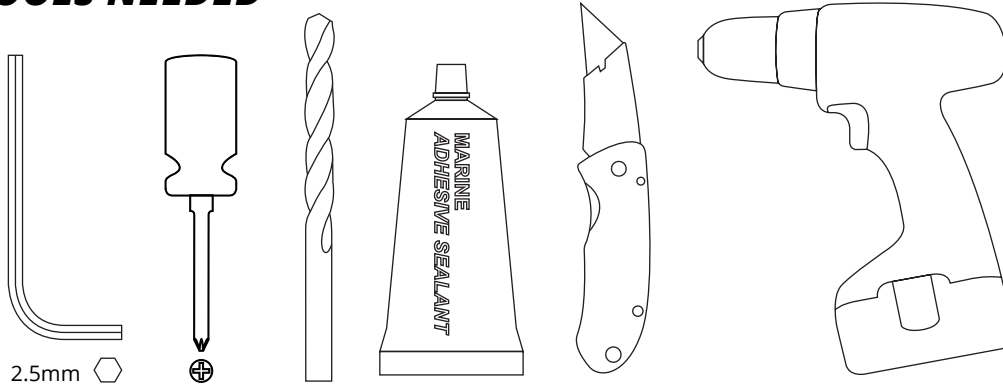

2.5mm

1

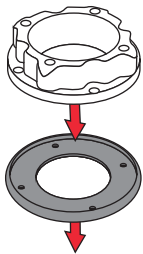

Place the plastic base onto the rubber base gasket. Be sure to line up the four screw holes.

2

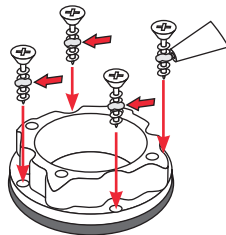

Drill pilot holes and secure the base. Apply marine adhesive sealant to the threads of the screws.

3

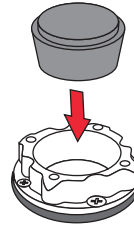

Insert the rubber grommet into the plastic base.

4

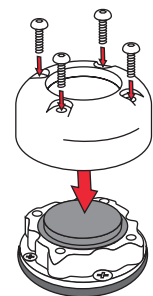

Line up the Cable Gland cover with the four holes in the plastic base and screw the bolts in with a 2.5mm wrench, compressing the rubber grommet.

5

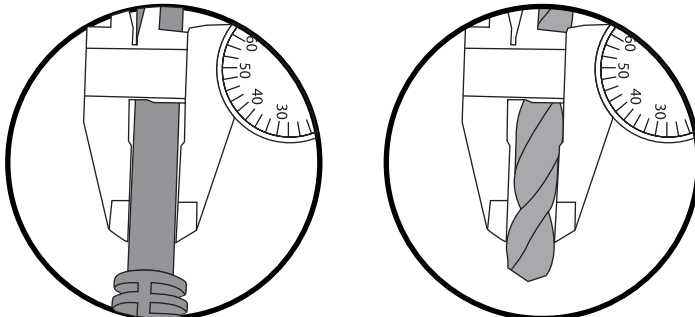

Measure your cable diameter and select the appropriate drill bit. For a 0.25" cable use a 9/32" or 7mm drill bit. For a 0.40" cable use a 7/16" or 11mm drill bit.

6

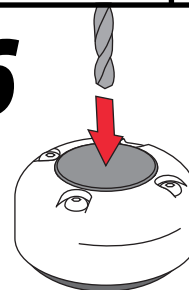

When drilling, the drill should be run repeatedly through rubber.

TIP#1

For a cleaner cut try this method for drilling your Cable Gland.

1



Take one of the four drill tubes (included with the Cable Gland). Double check to make sure the tube is the right diameter for your installation.

2

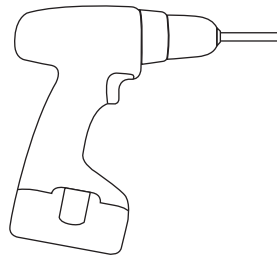

Put the tube into a drill.

3

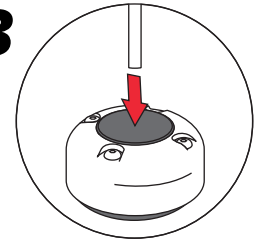

Apply small amount of soapy water to the tube and drill the Cable Gland.

TIP#2

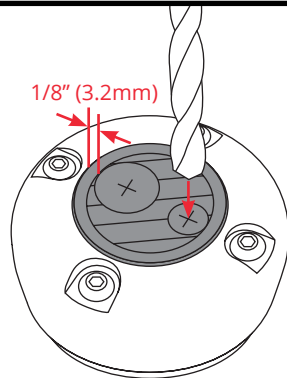

- Make sure that you do not drill within 1/8" (3.2mm) from the edge of the rubber grommet.
- A slightly larger drill is needed for drilling the rubber.

7

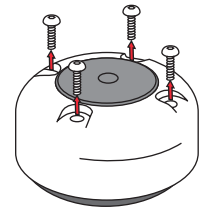

Remove the four screws using a 2.5 mm allen wrench.

8

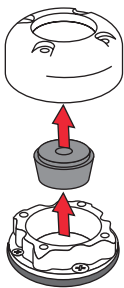

Remove the Cable Gland cover and rubber grommet.

9

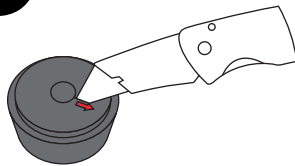

Using a sharp razor blade or knife, cut the rubber grommet from the cable hole outward.

10

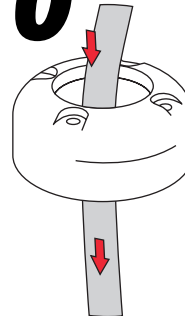

Slide the Cable Gland cover over the electronic cable.

11

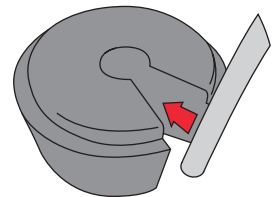

Wrap the rubber grommet around the electronic cable.

12

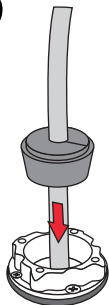

Insert the electronic cable and rubber grommet into the plastic base.

13

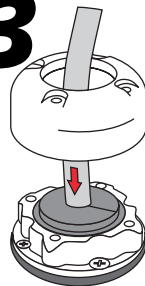

Slide the Cable Gland cover onto the plastic base making sure that all four bolt holes line up.

14

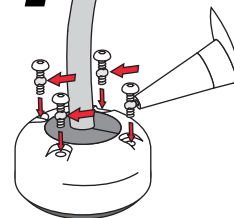

Apply marine sealant to the threads of the four bolts. Using an allen wrench fasten the four bolts down tightly.