

Frigoboat refrigeration system showing Cap Tube details

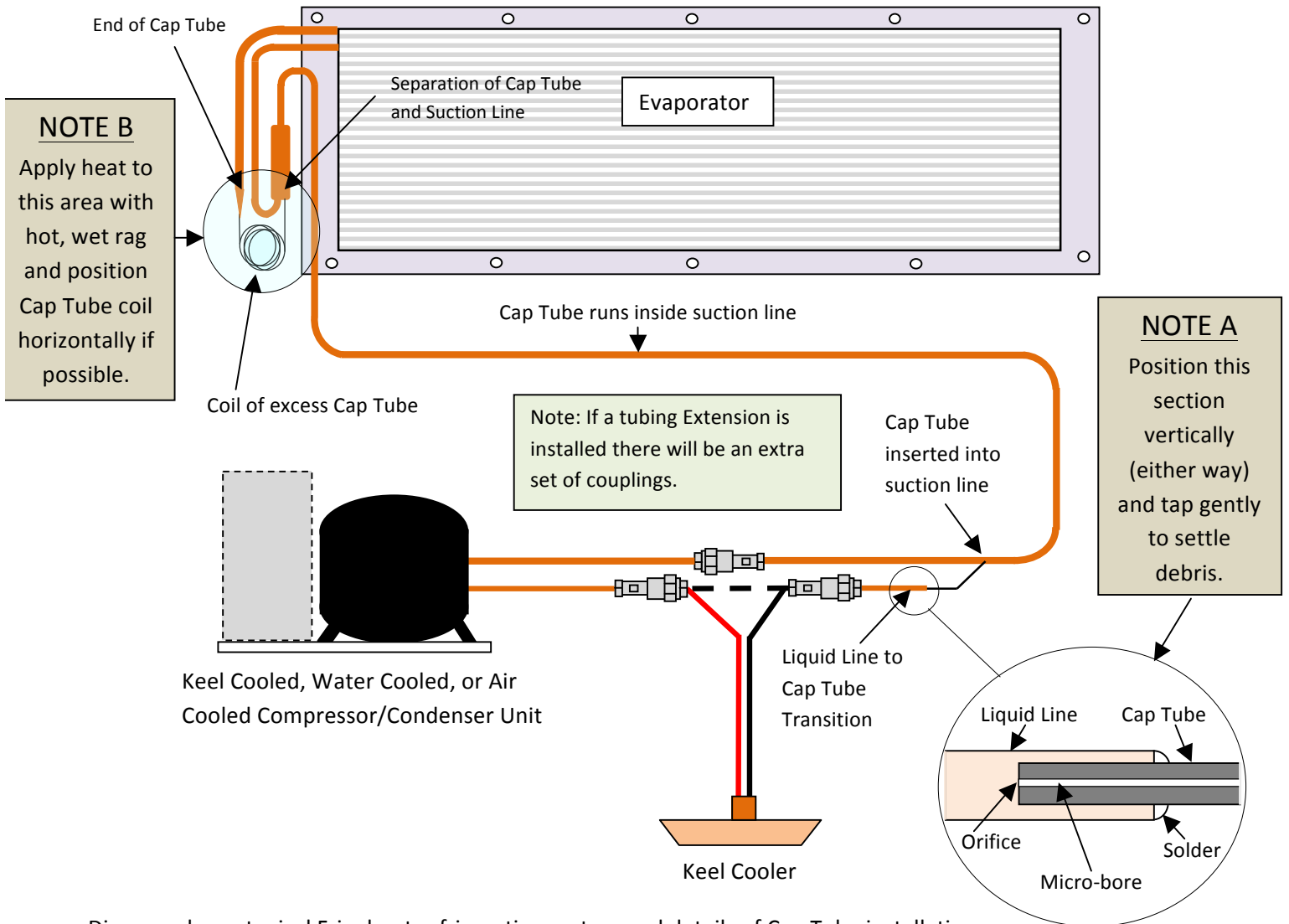

Diagram shows typical Frigoboat refrigeration system and details of Cap Tube installation. Evaporator shown is Flat (F) model, but instructions apply also to Bin (B) and Horizontal (H) models.

Recommended Procedure for Removing Moisture from System

1. Recover refrigerant
2. Evacuate system while applying heat to evaporator and tubing inside box
3. Run nitrogen through system
4. Repeat evacuation and heat process
5. Run nitrogen through system again
6. Add Filter/Drier, evacuate, and charge with refrigerant



Coastal Climate Control, Inc.

www.coastalclimatecontrol.com

info@coastalclimatecontrol.com

PO Box 4535 Annapolis MD 21403

301-352-5738