

### CAPRI 50-SSC

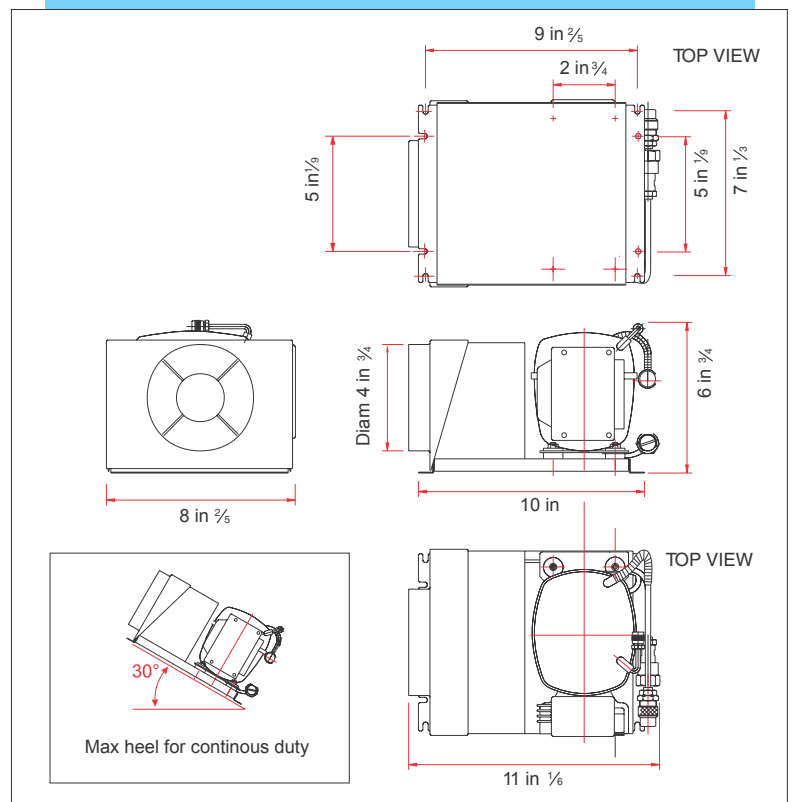

Part N. E52120SSC

- Danfoss compressor of the latest generation.
- Extremely compact dimensions.
- Maximum efficiency.
- Danfoss BD50 compressor with electrical consumption 25% lower than earlier compressor concepts.
- Equipped with Smart Speed Control.
- Forced air cooling.
- Precharged system with Frigoboat self sealing couplings.
- Configurations with evaporators for fridges up to 15 cu.ft. and freezer up to 5 cu.ft.
- Automatically runs on 12 or 24 volts.
- Automatic battery protection.
- Equipped with stainless steel fan shroud & reversible fan to allow warmed air to be exhausted or cooler air to be drawn in.
- Duct kit available - Part N. VNA023



### CAPRI 50-SSC

#### SYSTEM CONFIGURATION

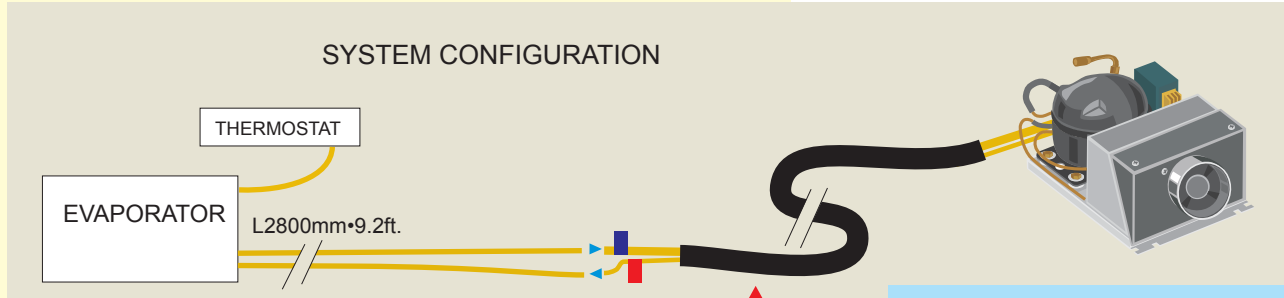

#### TECHNICAL CHARACTERISTICS\*

COMPRESSOR SPEED	2000	2300	2600	2900	3200	3500
CAPACITY BTU/H	332	360	403	431	453	500
CONSUMPTION (A/12V)	3.8	4.3	4.8	5.2	5.7	6.2

WEIGHT 12.7lbs. 5.8Kg  
 SHIPPING WEIGHT 14.5lbs. 6.6Kg

\*Under Average Conditions

#### PRECHARGED EXTENSIONS (Options)

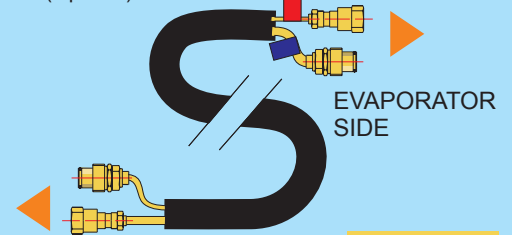

COMPRESSOR SIDE	L	Part N.
	3 ft	E50255
	6 ft	E50260
	10 ft	E50265

Part N. E52150

#### The Smart Speed Control

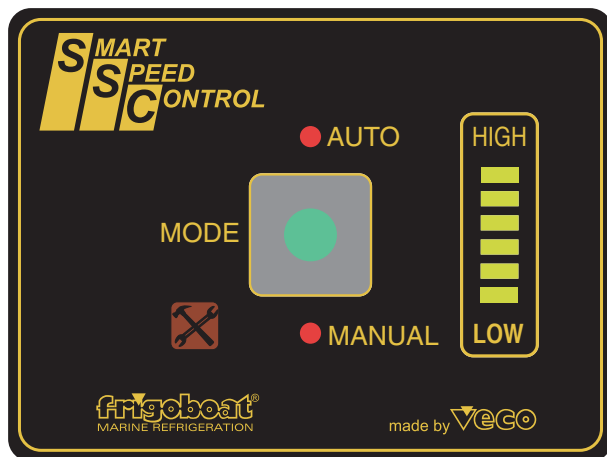

ACTUAL SIZE

#### Featuring:

- Compressor Protection.
- Automatic Speed Adjustment for Maximum Operating Efficiency.
- Manual High Speed Reset Feature (for ice box restocking).
- Many other features, see brochure for details.

#### THERMOSTAT



FRIDGE  
Part N. E250500  
  
FREEZER  
Part N. E250700



DOUBLE  
Part N. E261300



SPILOVER FAN & THERMOSTAT  
Part N. E26200



CAREL DIGITAL THERMOSTAT/THERMOMETER  
Part N. VNATA0625



VECO N.A. Annapolis MD

www.frigoboat.com E-mail: info@frigoboat.com