

MK3 v.2011 POWERBOARD CONNECTION

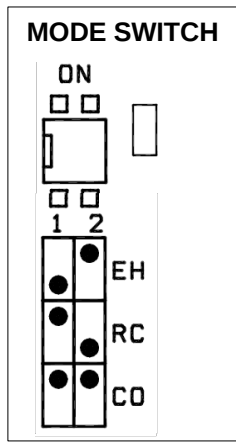

FUSE2 = 0,5 A

Move the JUMPER to Select TEMPERATURE Mode (°C-°F)

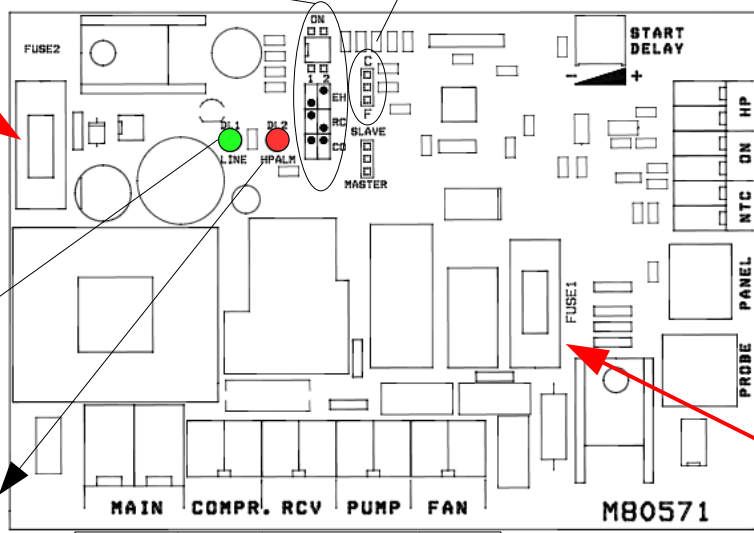

POWER LED (Line) ON – When Board is powered

HPS LED (HPALM) ON – When HPS is open = alarm engaged

FUSE1 = 6,3 A

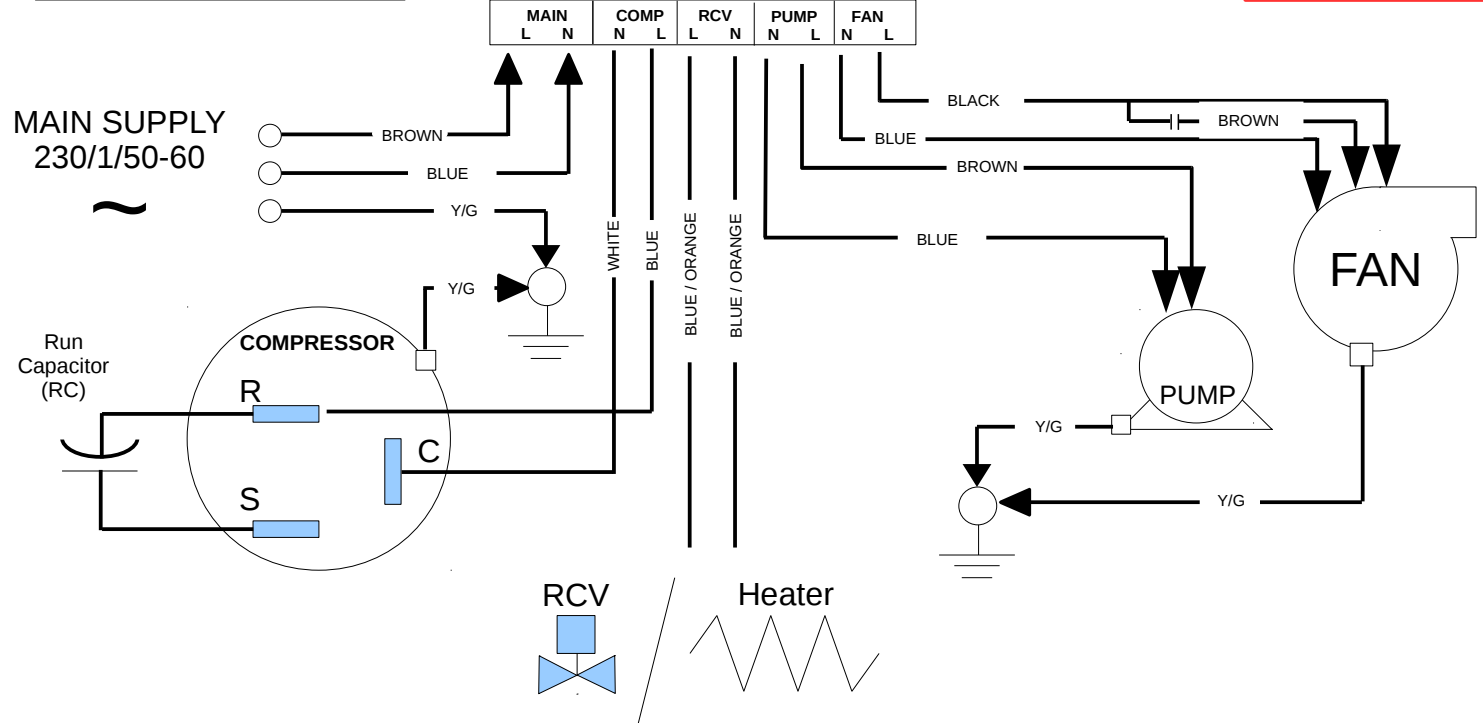
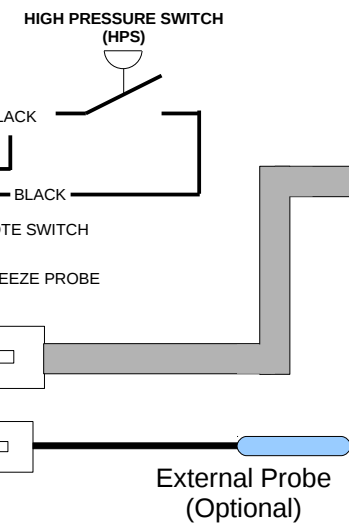

ATTENTION

SWITCH MODE FOR OLDER VERSION

DIP SWITCH LEGEND

- 1-ON / 2-ON = P0 = COOL ONLY Unit (CO)
- 1-ON / 2-OFF = P1 = Unit with ELECTRICAL HEATING (EH)
- 1-OFF / 2-ON = P2 = Unit with REVERSE CYCLE (RC)
- 1-OFF / 2-OFF = nP = No Program Selected



C845-02 05/2012