

Start Your A/C with Ease
on Generator or Inverter
with

EasyStart™

by  **MICRO-AIR**



Your A/C compressor motor current soars at startup. Compressor starts often draw 4 to 6 times the normal running current. This can cause lights to dim, generators to stall, breakers to trip, or marginal inverters to simply not work, and it may even damage other devices connected to your electrical system.

EasyStart is a low-cost solution to expensive generator replacements and costly inverter upgrades. EasyStart reduces starting current by a staggering 65-75% (of the LRA rating) and controls power throughout the start. Compressors start more quietly, and the power source work load is lighter with EasyStart.

EasyStart beats the competition

- Better performance & lower cost
- 70% average reduction from LRA (locked-rotor)
- IP65 weatherproof enclosure
- Far superior & totally different than a “hard start”
- Enhanced fault detection to protect the compressor
- Integrated short-cycle prevention
- Cost saving board-only models available

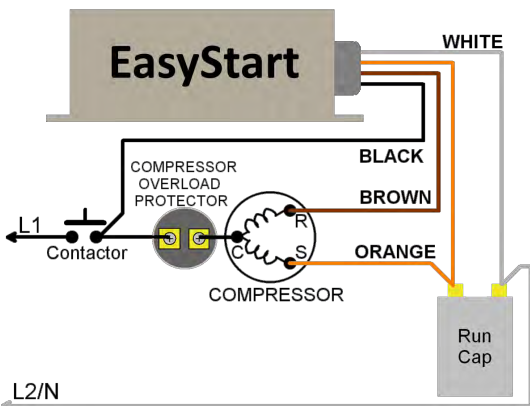

Models & Specifications

Voltage:	100-250VAC/50-60Hz/1Φ
ASY-364-X36 - 36kBTUs (3-ton) 25 FLA	Enclosure: 194L x 91W x 64H mm 7.64L x 3.58W x 2.50H in
	Harness: 40 in (1m)
ASY-368-X72 - 72kBTUs (6-ton) 36 FLA	Enclosure: 240L x 120W x 75H mm 9.45L x 4.72W x 2.95H in
	Harness: 32 in (0.8m)
ASY-366-X05 - 36kBTU 25 FLA board-only model	
ASY-366-X06 - 72kBTU 36 FLA board-only model	

Advantages

- Enables a weak power source to start & run your A/C that would otherwise have not, including utilities, shore cords, generators, and inverters (pure or modified sine).
- Optimizes itself by “learning” the compressor
- Compatible with any single-phase compressor, including reciprocating, rotary, and scroll.
- Can also be used on watermakers, air compressors, & most refrigeration equipment.

Available From:



Coastal Climate Control, Inc.

www.CoastalClimateControl.com - info@CoastalClimateControl.com
301-352-5738 - Annapolis MD USA

Features	EasyStart	Competitor
Start-Up Algorithm for Start Surge Reduction		
Lab Tested CE Compliance	✓	✓
Average start surge reduction to 65%	✓	✓
Average start surge reduction to 70%	✓	
Sophisticated, auto-learned 4-part start-up algorithm	✓	
One-Time Learning Algorithm for better shore power/generator transitions	✓	
Optimized to eliminate spikes during start-to-run transition	✓	
Individually optimized start-up profiles for 50Hz and 60Hz	✓	
Low sensitivity to momentary voltage dips during start-up	✓	
Auto-bleed of run cap voltage and compressor energy during shutdown	✓	
Reliably starts any 115V compressor on a Honda EU2000i in ECO Mode	✓	
Electronic Hardware		
Daughterboard & Low-Cost Board-Only solutions available	✓	
True 6 ton compressor support in largest model (38 FLA)	✓	
Precise Compressor Rotation/Phase Measurement	✓	
Fault Detection for Compressor/Wiring/Electronics Protection		
Stall Detection during start-up	✓	✓
Open-Overload Detection during start-up and run operation	✓	✓
Momentary Power Outage detection during run operation	✓	✓
4-Minute Shutdown and restart after fault	✓	✓
Anti-Short-Cycle Timer that keeps track of time when powered off	✓	
Sustained Over-Current detection during run operation	✓	
Fault LEDs on circuit board for easy determination of cause	✓	
Plastic Enclosure Solution		
Integrated 4-wire Harness	✓	✓
Multiple Sizes for compressor capacity ranges	✓	✓
Integrated Mounting Tabs	✓	
Removable Lid for troubleshooting via LEDs & for start cap servicing	✓	
Fully Weatherproof, No-Ingress Enclosure (IP65)	✓	
Lower Cost	✓	